



DECHLO RANGE

PUBLIC SWIMMING POOLS
WELLNESS AREAS
SPAS
THALASSOTHERAPY &
BALNEOTHERAPY
HYDROTHERAPY

UVGERMI®
 ULTRA NATURAL TECHNOLOGY
 www.uvgermi.fr

UVDECHLO CD600 ECOENERGY

Flow rate: from 300 to 450 m³/h

REF: 19000114

Automatic control using chloramine concentrations*

The **UVDECHLO CD600** reduces the level of combined chlorine in swimming pools through a photochemical action on all organochlorine compounds found in the water (monochloramine, dichloramine trichloramine). It also destroys Giardia and Cryptosporidium.



TECHNICAL SPECIFICATIONS



Equipment approved by the Ministry of Health under No. 050021

UV LAMP

Total electrical power:	1,800 Watts (3 lamps)
UV dose at the end of lamp service life:	60 mJ/cm ²
Lamp service life:	12,000 hours or 16 months

UV REACTOR

Treatment chamber:	Stainless steel 316L
Input/Output:	DN 300/PVC 315
Operating pressure:	2 bars

ELECTRICAL CABINET

Dimensions (mm):	600 x 800 x 400
Power supply:	400 V
Display:	Hour counter / Stop-start counter / Lamp replacement pre-alarm & alarm / Lamp defect / Chloramine level control (*analyser not supplied)

ASSOCIATED PRODUCTS

600 W UV lamp:	14000100
Quartz sleeve:	14000055
Seals (x 2):	15000204

UVDECHLO CD600 ECOENERGY

Flow rate: from 300 to 450 m³/h

REF: 19000114

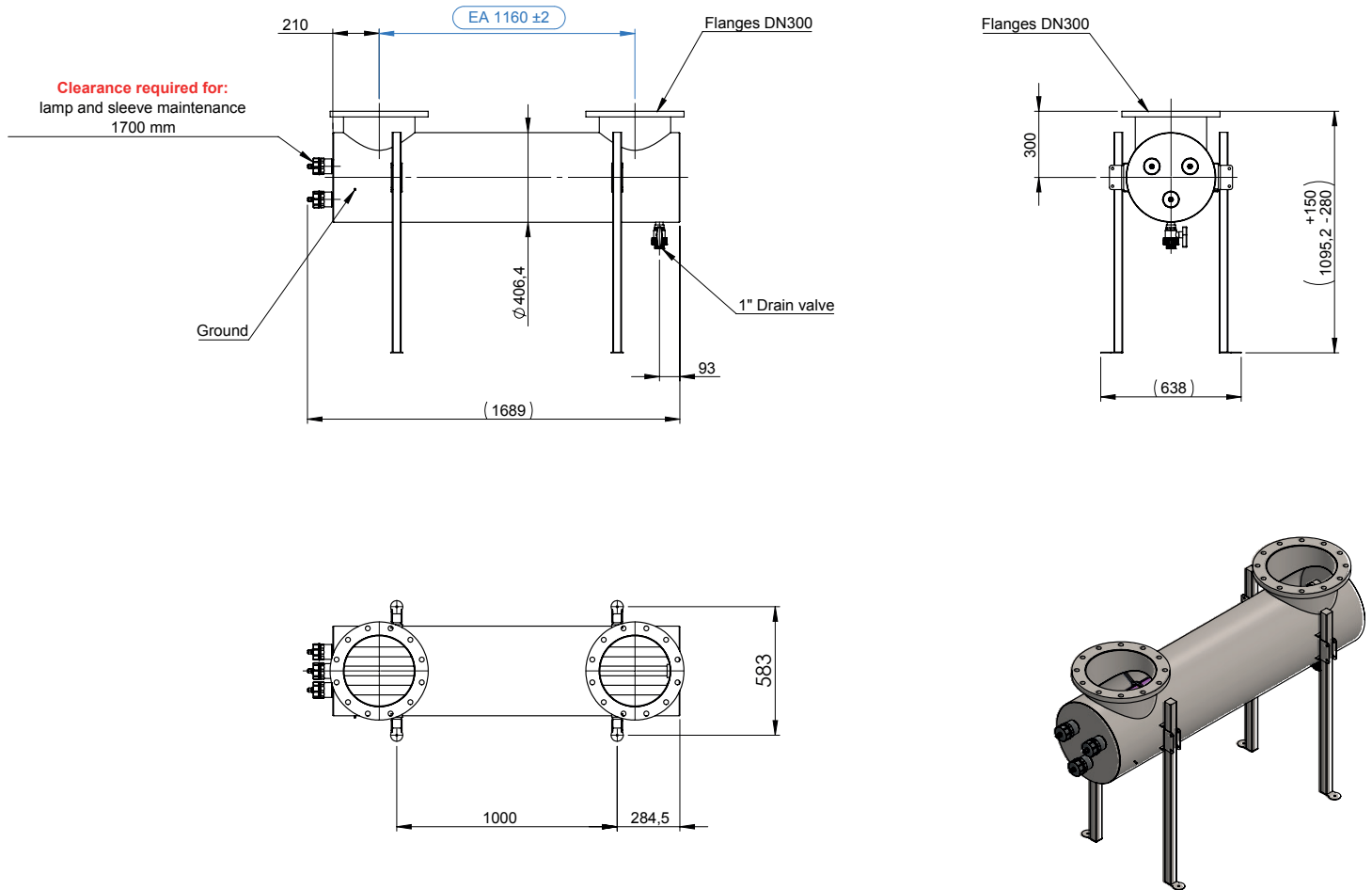

INSTALLATION

The dechloramination unit must be installed horizontally: water flow can be in either direction, but we recommend that the water flows in from the top and out from the top of the unit to avoid any accumulation of air in the treatment chamber and to ensure that it always remains full of water. Sufficient clearance must be provided along the dechloramination unit (1.70 m) to allow for maintenance and UV lamp replacement.

Filtration is required to remove suspended solids. The dechloramination unit is therefore installed after the pool filters, but before chlorine injection as the chlorine molecules can be degraded by UV radiation.

MAINTENANCE

Loss of efficiency occurs when the UV lamps reach the end of their service life (after 2 years of operation) or if one of them becomes defective. They must be replaced. The quartz sleeves make lamp replacement much easier: the unit does not have to be drained or dismantled. The dechloramination unit is equipped with several lamps, which must all be replaced at the same time.

The quartz sleeves may become clogged and should be cleaned once a year with a mild acid. Seals on the quartz sleeves must be replaced every time they are dismantled, and at least every two years.



UVGERMI SA, ZAC de la Nau, 19240 Saint-Viance, France | Tel: +33 (0) 555 881 888 | Email: contact@uvgermi.fr

www.uvgermi.fr

